

PM_{23c} | PM₄₃ | PM_{43c}

Parallel Port Option Board

Installation Instructions

Intermec Technologies Corporation

Worldwide Headquarters

6001 36th Ave.W.

Everett, WA 98203

U.S.A.

www.intermec.com

The information contained herein is provided solely for the purpose of allowing customers to operate and service Intermec-manufactured equipment and is not to be released, reproduced, or used for any other purpose without written permission of Intermec Technologies Corporation.

Information and specifications contained in this document are subject to change without prior notice and do not represent a commitment on the part of Intermec Technologies Corporation.

© 2012–2013 by Intermec Technologies Corporation. All rights reserved.

The word Intermec, the Intermec logo, Norand, ArciTech, Beverage Routebook, CrossBar, dcBrowser, Duratherm, EasyADC, EasyCoder, EasySet, Fingerprint, INCA (under license), i-gistics, Intellitag, Intellitag Gen2, JANUS, LabelShop, MobileLAN, Picolink, Ready-to-Work, RoutePower, Sabre, ScanPlus, ShopScan, Smart Mobile Computing, SmartSystems, TE 2000, Trakker Antares, and Vista Powered are either trademarks or registered trademarks of Intermec Technologies Corporation.

There are U.S. and foreign patents as well as U.S. and foreign patents pending.

Install the Parallel Port Option Board

Use these instructions to install the IEEE 1284 parallel port option board in Intermecc PM23c, PM43, and PM43c printers. You will find these items in the shipping box:

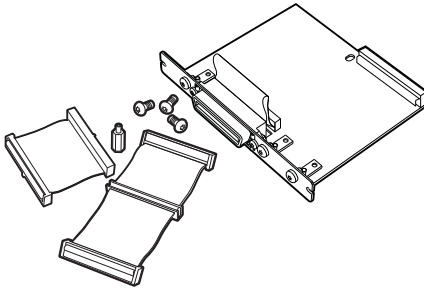

You will need the following tools to install the parallel port:

- T10 and T20 Torx screwdrivers
- Small wrench

To install the parallel port option board, you need to open the printer and physically install the board in the printer.



Warning

This module must only be installed by an authorized service technician.



Follow ESD
Procedures

Follow standard ESD guidelines to avoid damaging the equipment you are servicing.



Caution

Before you begin, turn off the printer and disconnect the power cord and communication cables.



Warning

The electronic compartment contains wires and components with dangerous voltage. Make sure that the printer is switched off and the power cord is disconnected before the cover is removed.

Open the Printer

You need to remove both the media cover and the electronics cover to install the parallel port option board.

To remove the media cover

- 1 Open the media cover.

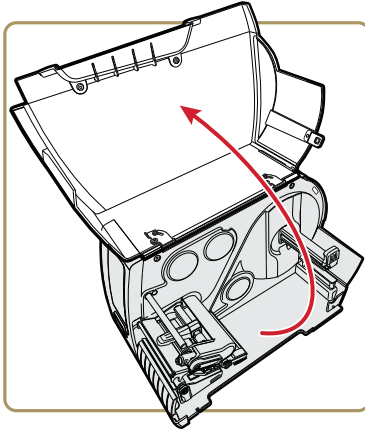

- 2 Use the small wrench to loosen the nut that secures the media cover latches in place.
- 3 Slide the latches counterclockwise into the open position.

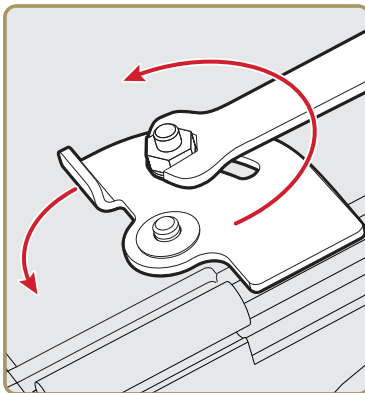

- 4 Close the media cover and lift it off the hinges.
- 5 Put the media cover aside on a soft cloth to avoid scratches.

To remove the electronics cover

- 1 Use a T20 Torx screwdriver to remove the two screws that secure the electronics cover to the inside of the printer base.

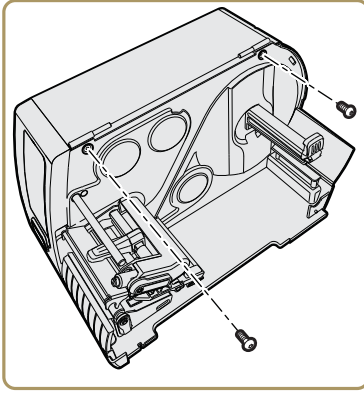

- 2 Use a T20 Torx screwdriver to remove the two screws located on the outside of the electronics cover.

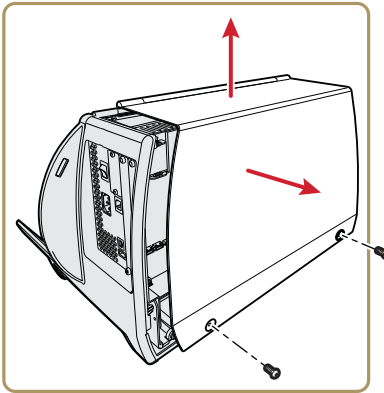

- 3 Remove the electronics cover, and put the cover aside on a soft cloth to avoid scratches.

To install the parallel port option board

- 1 On the back of the printer, remove the two screws that secure the cover plate to the printer, and remove the cover plate.

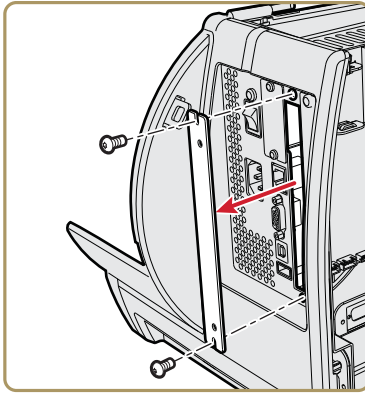

- 2 Attach the spacer screw to the center of the printer main board.
- 3 Insert the parallel port option board into the printer and use the T20 Torx screwdriver to secure the board assembly to the printer with the two Torx screws removed in Step 1.

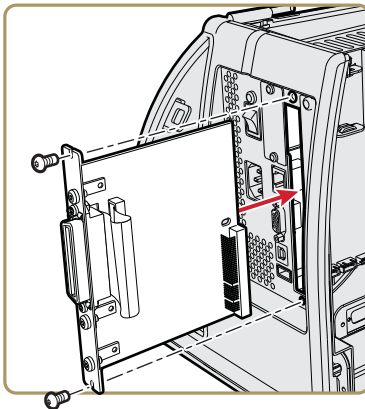

- 4 Use the T20 Torx screwdriver to secure the board assembly to the spacer screw with a Torx screw.

- 5 Insert the single or dual option board cable into the 80-pin connector on the printer main board.

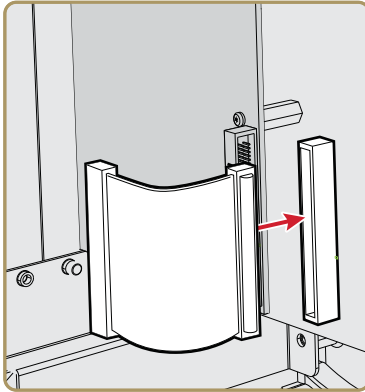

- 6 Insert the other end of the option cable into the 80-pin connector on the parallel port option board.



Note: You may need to use the dual option cable to connect to the main board depending on which slot you use for the parallel port option board.

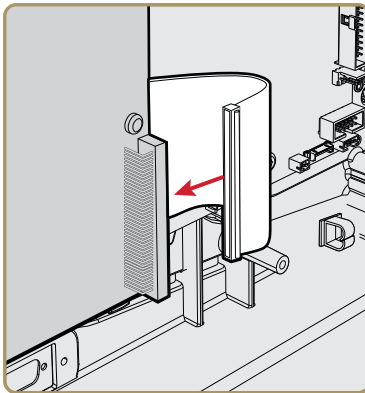

- 7 Replace the electronics cover.
- 8 Replace the media cover.



Worldwide Headquarters
6001 36th Avenue West
Everett, Washington 98203
U.S.A.

tel 425.348.2600

fax 425.355.9551

www.intermec.com

© 2013 Intermec Technologies
Corporation. All rights reserved.



PM23c, PM43, PM43c Parallel Port Option Board Installation Instructions



P/N 931-100-002