

H-Class™

Peel & Present Option ■ ■ ■

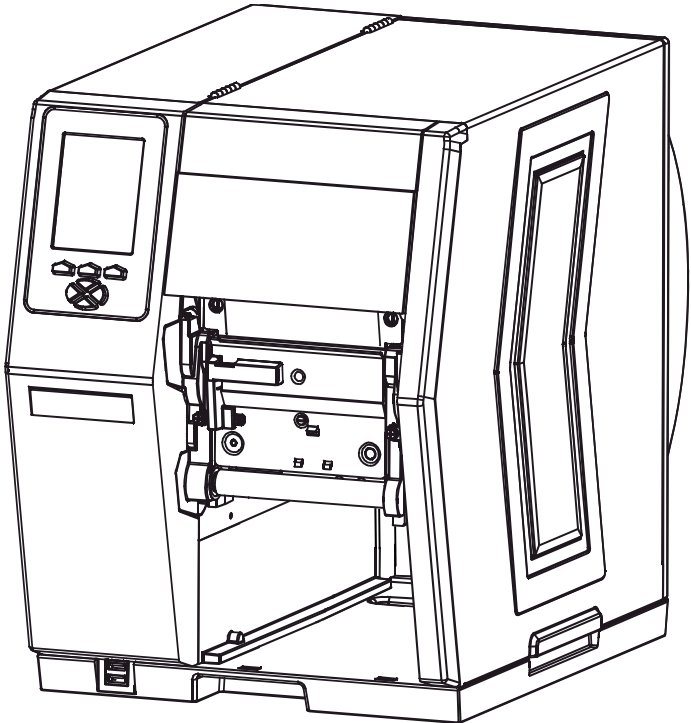

right by our customers. ■ ■ ■

datamax·o'neil

Overview

This document describes the contents, installation, and use of the Peel & Present option for the H-Class printer. After verifying the contents of the kit and the tools needed, follow the steps below to install and begin using the option. A maintenance procedure is also included, so keep this documentation for future reference.



For your safety and to avoid equipment damage, always turn 'Off' power and unplug the printer's power cord before beginning this installation and when performing service.

Contents of the Peel & Present Option

This kit contains the following item:

- Peel & Present Assembly

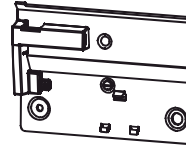

Tools Required

To install this option, you will need a standard screwdriver.

Step 1: Preparing the Printer

- A)** Turn 'Off' the **Power Switch** and unplug the power cord from the **AC Receptacle**.

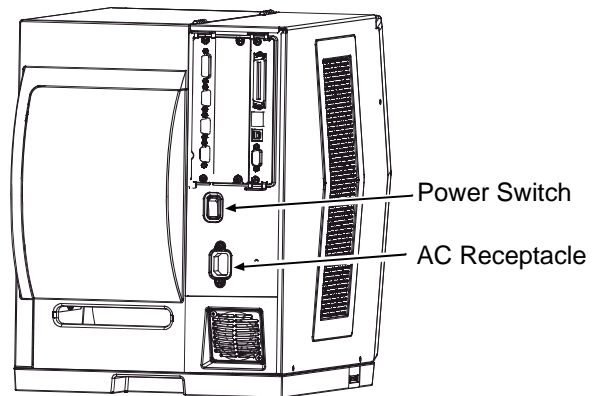

- B)** Press down on the **Catch**, then pull forward to remove the **Door**.

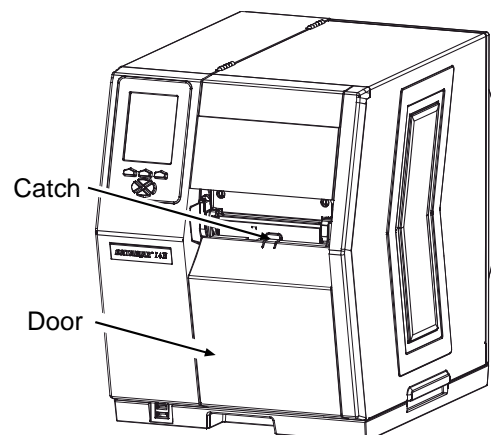

C) Raise the **Access Cover** and remove your media from the printer.

D) Remove the **Thumbscrew** and **Tear Plate**. (Alternately, if equipped with an Arc Plate, Present Sensor, or Cutter, remove that device.)

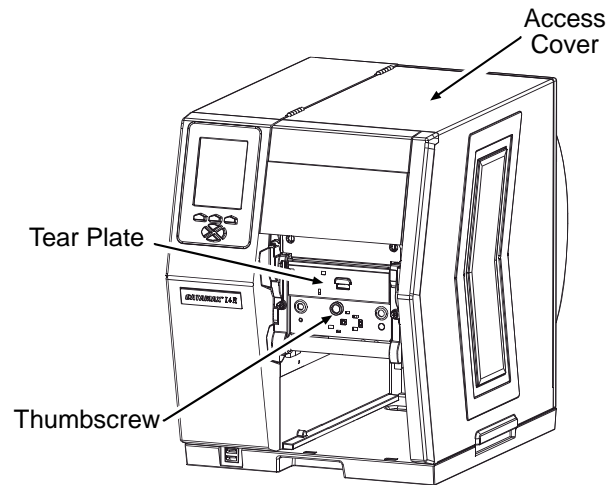

Step 2: Installing the Peel & Present Assembly

A) Carefully press the **Peel & Present Assembly** into the **Front Plate Connector**.

B) Tighten the **Mounting Screw** to secure the **Peel & Present Assembly** to the printer.

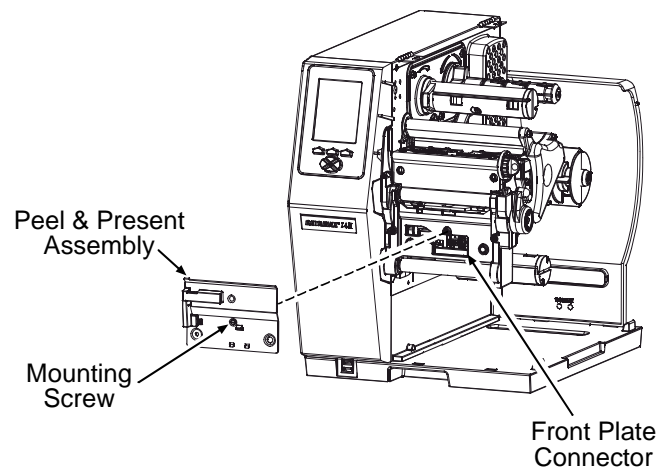

Step 3: Using the Option

During operation, labels will be peeled from the backing material and dispensed “on-demand” – that is, subsequent printing will occur only after a previously printed label has been removed from the printer. As a reminder, “REMOVE LABEL” will be displayed to prompt you when a label awaits removal.

Begin using the option as follows:

A) Load **Media** (see the *Operator's Manual* for details). Extend 20 inches (50 cm) of **Media** from the printer.

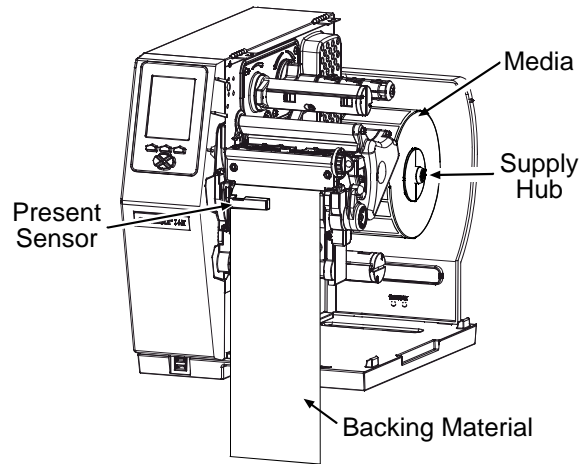

B) Remove the labels from this extended portion of media, leaving only the **Backing Material**. Crease the leading edge of this **Backing Material** and route it behind the **Present Sensor** (on the Peel & Present Assembly).

C) Route the **Backing Material** under the **Assist Roller** and the **Internal Rewinder**.

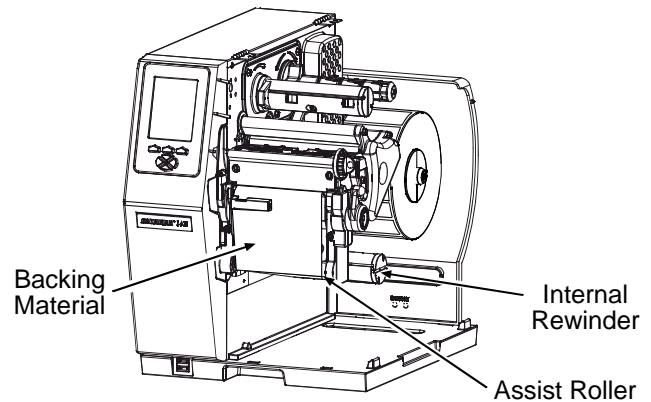

D) Wrap the **Backing Material** in a counterclockwise direction around the **Rewinder Hub** and insert the **creased leading edge** into one of its **Slots**. Insert the **Media Clasp** (Item ⑥) into the **Slot** over the **creased leading edge** of the **Backing Material** and around the **Rewinder Hub**.

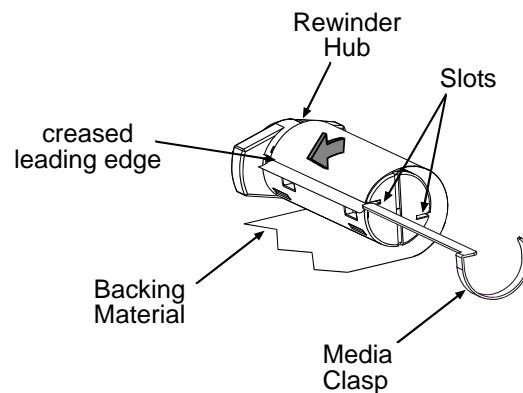

E) Close the Access Cover, plug the power cord into the AC Receptacle, and turn 'On' the Power Switch.

F) Ensure that **READY** is displayed on the **Front Panel** then press the **FEED Key**, and proceed according to your observations:

- If **REMOVE LABEL** is displayed on the **Front Panel**, this completes the installation; or,
- If **REMOVE LABEL** is not displayed on the **Front Panel**, proceed to Step 4: "Configuring the Printer."

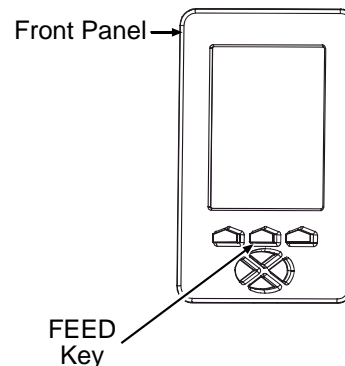

✓ Notes: (1) The operation of the Present Sensor on this option can also be controlled by host software commands, so ensure that your labeling program is properly configured for use when sending label formats to the printer.
(2) If this option is removed with power applied, the printer will behave as if a label awaits removal; to restore normal operation, cycle power to the printer.

Step 4: Configuring the Printer

While the Peel & Present option is a plug and play device, this step may be necessary if the printer's default configuration has been changed. Follow the steps below to configure the printer:

✓ Note: In the following procedure, consult the Operator's Manual for detailed front panel instructions.

- A) Press the **MENU Button** on the printer's front panel.
- B) Using the **DOWN Button**, scroll to **PRINTER OPTIONS** then press the **RIGHT Button**.
- C) Using the **DOWN Button**, scroll to **PRESENT SENSOR** then press the **ENTER Key**.
- D) Using the **DOWN Button**, scroll to **MODE** then press the **ENTER Key**.
- E) Using the **DOWN Button**, scroll to **AUTO** then press the **ENTER Key**.
- F) Press the **EXIT Key** then, at the **SAVE CHANGES?** prompt, select **YES** to complete the installation.
- G) Turn the **Power Switch** 'Off' and 'On' to reset the printer and complete the configuration.

✓ Note: If the printer fails to separate the labels from the backing material, the Internal Rewinder may need to be enabled. Using the procedure above as a guide, press the **MENU Button**, scroll to **PRINTER OPTIONS**, then to **REWINDER**, and select **AUTO**. Afterward, press the **EXIT Key** and save your changes when prompted.

Maintaining the Peel & Present Assembly

To ensure trouble free operation, the Peel & Present Assembly should be cleaned after every 100,000 inches (254,000 cm) of media use. This interval depends on the label adhesive, where “gummy” adhesives may require more frequent cleaning. (To easily track label usage, go to SYSTEM SETTINGS → MEDIA COUNTERS in the printer’s menu system.) Clean the assembly as follows:

1. Turn ‘Off’ the Power Switch and unplug the power cord from the AC Receptacle. Raise the Access Cover and remove the media from the printer.
2. Remove the **Peel & Present Assembly** from the printer.
3. Using compressed air or a soft brush, clean the **Sensors**.

Note: For cleaning heavy deposits, isopropyl alcohol can be used – provided it is carefully applied using a cotton swab, and then allowed to dry before reconnecting the option to the printer.

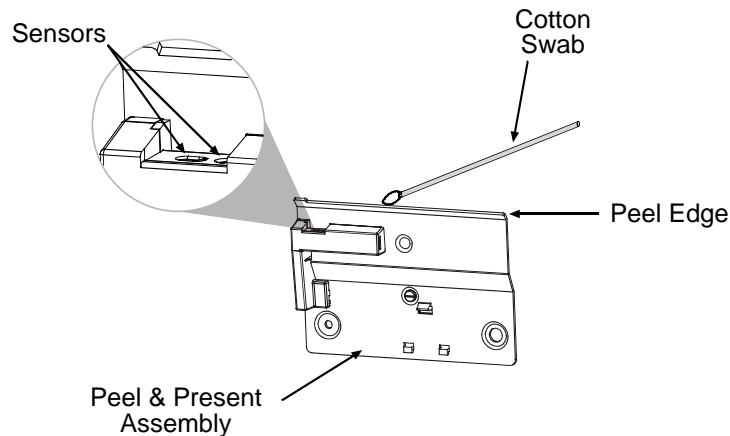

4. Using a **Cotton Swab** *dampened* with isopropyl alcohol, wipe the **Peel Edge** clean.
5. Reinstall the **Peel & Present Assembly** onto the printer.
6. Reload media, and close the Access Cover to complete the procedure.

